

PAC-94ID

- fast quadrature counter, $f_{inp.} = 250$ kHz
- 1 pulse quadrature counting input
- 2 programmable function inputs
- 4 relay (or OC) outputs
- programmable marker function

The PAC-94ID counters are intended for tandem operation with the incremental encoders featuring quadrature outputs. The counters feature 4 relays (or OC outputs) with independently settable activation thresholds, which can be used to control external devices in one of two available operation modes. The counters also have 2 inputs with programmable function.

- fast quadrature input up to 250 kHz,
- 2 inputs with programmable function,
- 5 counter reset sources,
- automatic reset option,
- password protection,
- relays (or OC) operation time programmable to 99 min.,
- programmable multiplier, divider and offset (4 profiles),
- programmable decimal point position,
- ACCESS option - easy threshold modification,
- available with AC and DC power supply versions.

Exemplary pin assignment

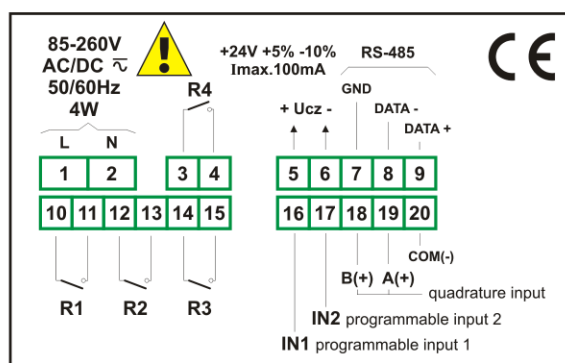

Ordering

PAC-94ID-164X-1-X-XX5-N1

options:

- 00 : no options
- 01 : IP 65

power supply:

- 3 : 24V AC/DC
- 4 : 85...260V AC/DC

type of outputs:

- 1 : REL
- 2 : OC



Typical applications

1. Measuring the length of wound material plus control of the cutting knife actuator according to predefined parameters, control of the material travel drive and alarm signalling.

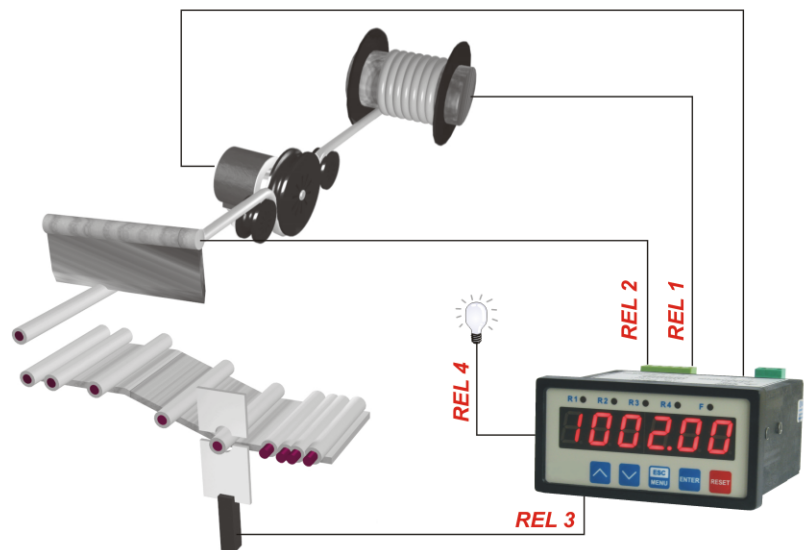

Technical data

Power supply: 19...50V DC; 16...35V AC or 85...260V AC/DC

Power consumption: for 85...260V AC/DC and 16...35V AC power supply: max. 4,5 VA; 19...50V DC power supply: max. 4,5 W

Display: LED, red, 6 x 13 mm high

Inputs: pulse, galvanically isolated

- A and B inputs - quadrature, counting
- IN1 input - programmable
- IN2 input - programmable
- COM input - common

Input levels: low: 0...1 V
high: 10...30 V (max. 12 mA for 24V)

Max. input frequency: 250 kHz

Displayed values range: current values counter -99999...999999 + decimal point
cycles counter ("normal" mode) 0...999999
cycles counter ("marker" mode) -99999...999999 + decimal point
totalizer counter -99999999999...99999999999

Outputs: 4 relays 1A/250V AC ($\cos\phi=1$) or the OC 30mA/30VDC/100mW

Transducer power supply output: 24V DC +5%, -10% / max. 100 mA, stabilized, not insulated from communication interface

Communication interface: RS-485, 8N1 and 8N2, 1200 bit/s...115200 bit/s, Modbus RTU (not galvanically isolated)

Data memory: non-volatile memory, EEPROM type

Operating temperature: 0...50°C

Storage temperature: -10...70°C

Protection class: IP 65 (front side when an additional frame is installed); IP 40 (front side); IP 20 (case and connection clips)

Case: board

Case material: NORYL - GFN2S E1

Case dimensions: 96 x 48 x 100 mm

Panel cut-out dimensions: 90,5 x 43 mm

Installation depth: min. 102 mm

Board thickness: max. 5 mm